

S-Type Alloy Steel Load Cell



FEATURES

- Capacities 1500 to 5000kg
- Alloy steel construction
- Sealing: welded to IP67
- S-Type design for use in tension and compression
- Choice of mounting threads Metric or Unified systems
- Six wire cable (sense circuit)

OPTIONAL FEATURE

- EEx ia IIC T6-ATEX hazardous area approval

DESCRIPTION

Model 619 is a low cost tension-compression load cell made from nickel plated alloy steel and has bonded covers for additional protection. It is suitable for use in a wide range of weighing, process weighing, force measurement and industrial process control applications.

Protected to meet IP67 requirements, the construction of the 619 load cell allows its use in most industrial process applications.

For IP68 requirements, select the fully-welded stainless steel model 620,

which shares the same dimensions as model 619.

The additional sense wires compensate for changes in lead resistance due to temperature change and/or cable extension. Complete compensation of changes in lead resistance is achieved by feeding this voltage into appropriate electronics.

APPLICATIONS

- Hopper (tank weighing)
- Hybrid scales
- Belt weighing
- Lever arm conversions
- Material testing machines
- Vibrations filling equipment
- Dynamometers

OUTLINE DIMENSIONS in mm

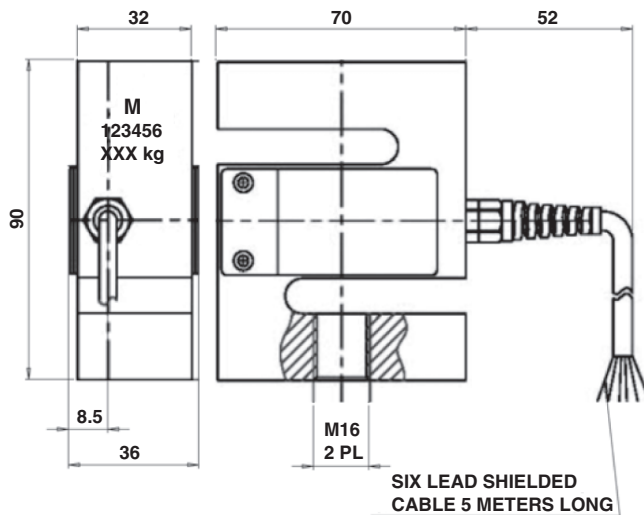

1500, 2000kg cell outline

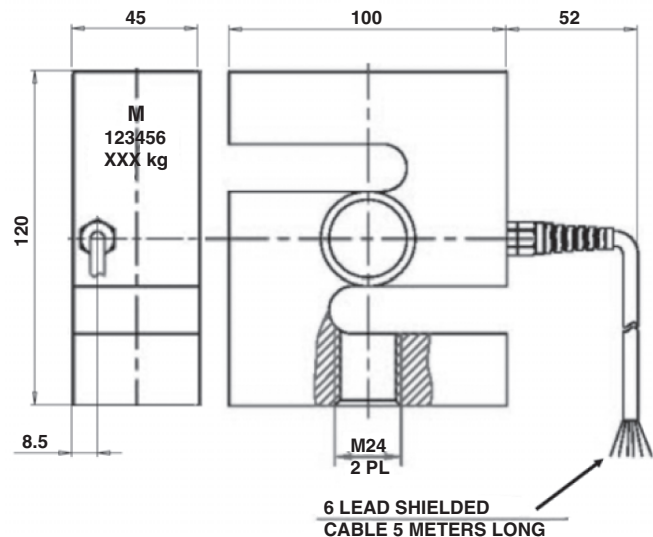

3000, 5000kg cell outline

SPECIFICATIONS

PARAMETER	VALUE		UNIT
Rated capacity-R.C. (E_{max})	1500, 2000, 3000, 5000		kg
Accuracy class	E	G	
Maximum no. of intervals (n)	1000	3000	
Rated output-R.O.	2.0		mV/V
Rated output tolerance	0.002		±mV/V
Zero balance	0.2		±mV/V
Zero Return, 30 min.	0.050	0.0170	±% of applied load
Total Error	0.050	0.020	±% of rated output
Temperature effect on zero	0.030	0.0040	±% of rated output/°C
Temperature effect on output	0.0030	0.0012	±% of applied load/°C
Temperature range, compensated	-10 to +40		°C
Temperature range, safe	-20 to +70		°C
Maximum safe central overload	150		% of R.C.
Ultimate central overload	300		% of R.C.
Excitation, recommended	10		Vdc or Vac rms
Excitation, maximum	15		Vdc or Vac rms
Input impedance	385±15		Ohms
Output impedance	350±3		Ohms
Insulation resistance	>2000		Mega-Ohms
Cable length	5.0		m
Cable type	6 wire, braided, PVC, dual floating screen		Standard
Construction	Nickel plated alloy tool steel		
Environmental protection	IP67		

Wiring Schematic Diagram

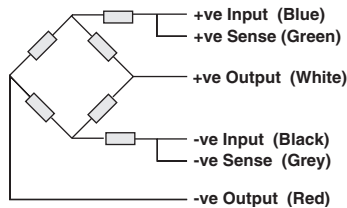



Notice

Specifications of the products displayed herein are subject to change without notice. Vishay Intertechnology, Inc., or anyone on its behalf, assumes no responsibility or liability for any errors or inaccuracies.

Information contained herein is intended to provide a product description only. No license, express or implied, by estoppel or otherwise, to any intellectual property rights is granted by this document. Except as provided in Vishay's terms and conditions of sale for such products, Vishay assumes no liability whatsoever, and disclaims any express or implied warranty, relating to sale and/or use of Vishay products including liability or warranties relating to fitness for a particular purpose, merchantability, or infringement of any patent, copyright, or other intellectual property right.

The products shown herein are not designed for use in medical, life-saving, or life-sustaining applications. Customers using or selling these products for use in such applications do so at their own risk and agree to fully indemnify Vishay for any damages resulting from such improper use or sale.