

Low-Profile Single Point



FEATURES

- Capacities: 0.6 to 200kg
- Small size with low profile
- Anodized aluminum
- NTEP Class III 5000S approval from 3kg to 30kg
- OIML C3 approval
- Platform size: 16"x16"/ 40cm x 40cm

OPTIONAL FEATURE

- FM approval available

DESCRIPTION

LPS is designed for electronic scales and platform scales where only one load cell can be used and low profile is required. It is the lightest model of Celtron single point load cell family. The design is most suitable for mass production operations.

LPS is constructed of anodized aluminum and is fully potted IP66 levels, providing excellent protection against moisture ingress.

APPLICATIONS

- Packaging machines
- Dosing/filling
- Belt scales/conveyor scales
- In-motion check weigher
- Retail scales/counting scales

OUTLINE DIMENSIONS

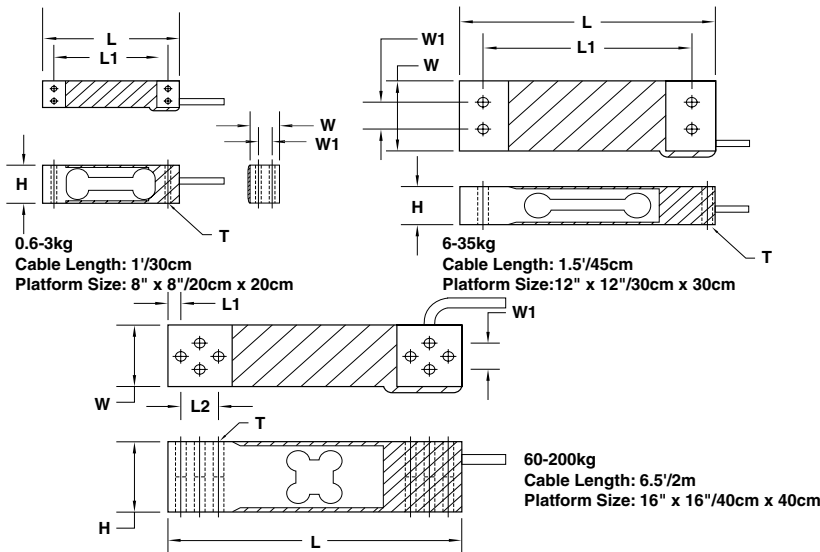

Wiring diagram

- + Excitation Red
- Excitation Black
- + Signal Green
- Signal White

CAPACITY (kg)		L	L1	L2	W	W1	H	T
0.6/1/2/3	mm	70.0	58.0	---	15.0	7.0	22.0	M3 x 0.5
	(inch)	2.76	2.28	---	0.59	0.28	0.87	
6/10/15/20	mm	130.0	106.0	---	30.0	15.0	22.0	M6 x 1.0
	(inch)	5.12	4.17	---	1.18	0.59	0.87	
30/35	mm	130.0	106.0	---	40.0	15.0	22.0	M6 x 1.0
	(inch)	5.12	4.17	---	1.57	0.59	0.87	
60/100/200	mm	150.0	7.0	19.0	35.0	15.0	40.0	M6 x 1.0
	(inch)	5.91	0.28	0.75	1.38	0.59	1.57	

**SPECIFICATIONS**

PARAMETER	VALUE			UNIT
	NTEP III	Non-Approved	C3	
NTEP/OIML Accuracy class				
Maximum no. of intervals (n)	5000 single*	1000	3000**	
$Y = E_{\max}/V_{\min}$	8000	5000	8000	Maximum available
Standard capacities (E_{\max})	0.6, 1, 2, 3, 6, 10, 15, 20, 30, 35, 60, 100, 200			kg
Rated output-R.O.	2.0***			mV/V
Rated output tolerance	10			±% of rated output
Zero balance	1			±% of rated output
Non linearity	0.025	0.030	0.020	±% of rated output
Hysteresis	0.025	0.030	0.020	±% of rated output
Non-repeatability	0.020			±% of rated output
Creep error (20 minutes)	0.030	0.030	0.017	±% of rated output
Zero return (20 minutes)	0.030	0.030	0.017	±% of rated output
Temperature effect on min. dead load output	0.0026	0.0026	0.014	±% of rated output/°C
Temperature effect on sensitivity	0.0015	0.0015	0.008	±% of applied load/°C
Compensated temperature range	-10 to +40			°C
Operating temperature range	-20 to +60			°C
Safe overload	150			% of R.C.
Ultimate overload	200			% of R.C.
Excitation, recommended	10			Vdc or Vac rms
Excitation, maximum	15			Vdc or Vac rms
Input impedance	410±10			Ohms
Output impedance	350±3			Ohms
Insulation resistance	>5000			Mega-Ohms
Construction	Anodized aluminum			
Environmental protection	IP66			

* Capacities 3-30kg

** Capacities 6-35kg

*** 1mV/V for 1kg and below

All specifications listed subject to change without notice.

FM Approval

Intrinsically Safe: Class I, II, III; Div. 1 Groups A-G

Non-Incendive: Class I; Div. 2 Groups A-D

VISHAY TRANSDUCERS (VT) SALES OFFICES

VT Americas
City of Industry, CA
PH: +1-626-858-8899
FAX: +1-626-332-3418
vt.us@vishaymg.com

VT Netherlands
Breda
PH: +31-76-548-0700
FAX: +31-76-541-2854
vt.nl@vishaymg.com

VMG UK
Basingstoke
PH: +44-125-646-2131
FAX: +44-125-647-1441
vt.uk@vishaymg.com

VMG Israel
Netanya
PH: +972-9-863-8888
FAX: +972-9-863-8800
vt.il@vishaymg.com

VMG Germany
Heilbronn
PH: +49-7131-3901-260
FAX: +49-7131-3901-2666
vt.de@vishaymg.com

VT China
Tianjin
PH: +86-22-2835-3503
FAX: +86-22-2835-7261
vt.prc@vishaymg.com

VMG France
Chartres
PH: +33-2-37-33-31-20
FAX: +33-2-37-33-31-29
vt.fr@vishaymg.com

VT Taiwan*
Taipei
PH: +886-2-2696-0168
FAX: +886-2-2696-4965
vt.roc@vishaymg.com
*Asia except China



Notice

Specifications of the products displayed herein are subject to change without notice. Vishay Intertechnology, Inc., or anyone on its behalf, assumes no responsibility or liability for any errors or inaccuracies.

Information contained herein is intended to provide a product description only. No license, express or implied, by estoppel or otherwise, to any intellectual property rights is granted by this document. Except as provided in Vishay's terms and conditions of sale for such products, Vishay assumes no liability whatsoever, and disclaims any express or implied warranty, relating to sale and/or use of Vishay products including liability or warranties relating to fitness for a particular purpose, merchantability, or infringement of any patent, copyright, or other intellectual property right.

The products shown herein are not designed for use in medical, life-saving, or life-sustaining applications. Customers using or selling these products for use in such applications do so at their own risk and agree to fully indemnify Vishay for any damages resulting from such improper use or sale.